



**Scattered Radiation Protection
for Femoral and Radial Access**

MAVIG



1980

Coronary catheterisation was being increasingly performed as it was finally possible not just to diagnose patients using this technique, but also to treat them as well.

- ▶ **Cardiac catheterisation labs are installed in more and more hospitals.**

1994

MAVIG develops its first protective shield with a body-shaped cut-out.

The uniquely formed shield **reduces the exposure** of the examiner/surgeon **by a factor of 3 – 5.**



A Short Time Later - 1995

German guidelines stipulates that X-ray facilities for coronary angiographies and cardiology interventions must have fixed radiation protection systems, consisting of a protective shield and lower body protection with a removable upper part.

- ▶ **These protective measures have now been adopted as standard practise in most of the world.**



The Present

New Insights

The choice of access via the femoral artery or the radial artery currently still varies by country. However, there has been a noticeable trend of a significant increase in radial access.

The challenge of finding a functional radiation protection solution appropriate for both access points led to detailed study of the current situation. The outcome was that the current standard could be optimised considerably.



In order to further develop today's standard practise, MAVIG defined the following

Objectives:

I. Elimination of Underpassing Radiation	Pages 06 - 11
II. Reduction of the Exposure Dose <i>of the examiner, including for access via the radial artery</i>	Pages 12 - 13
III. Optimal Shielding <i>including for examiners who are tall</i>	Pages 14 - 15
IV. Increased Freedom of Movement and Enlarged Protective Zone <i>for examiners, co-examiners and assistants</i>	Pages 14 - 15

2014 - New Development from MAVIG

Objectives I – IV above were achieved with the aid of four measures, taking into account the requirements of the physical conditions in the room and work routine during coronary angiographies and cardiology interventions.

*The **result** of MAVIG's new development is a new, innovative **radiation protective shield** with an **overlapping panel curtain** and ergonomically fitted **radiation protective drapes.***

A person wearing blue scrubs is shown from the side, adjusting an orange protective apron on a hospital bed. The apron has a grey waistband with silver fasteners. A clear plastic shield is visible in the background, attached to a metal stand. The scene is set in a clinical environment with a light-colored wall and a dark monitor in the background.

Designed by MAVIG with Safety in Mind.



CHALLENGE

Escaping Radiation from Below

when using one of today's standard radiation protective shields
without a curtain

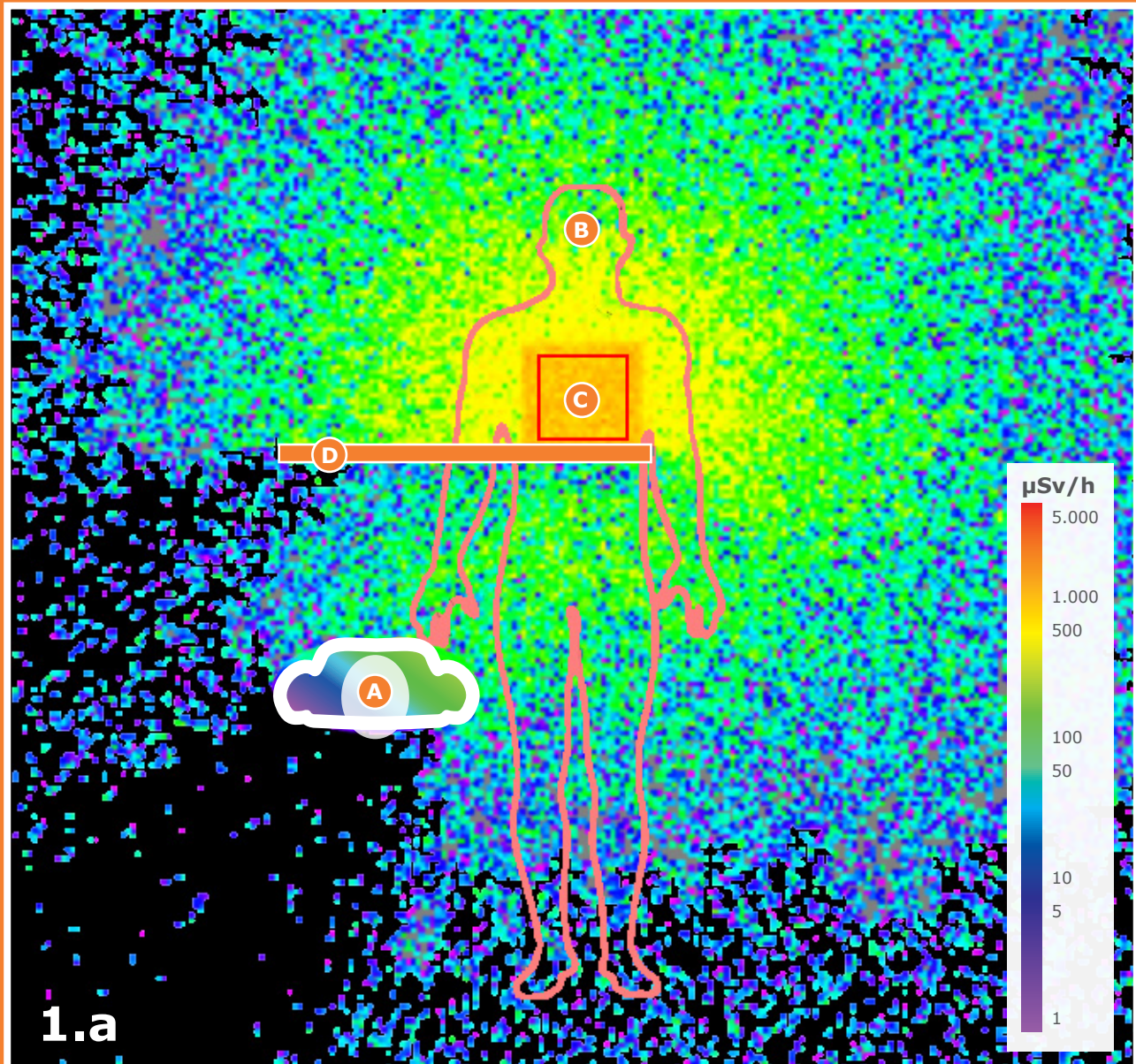

This Monte Carlo simulation allows a visualisation of the scattered radiation that passes through the patient's body and is released behind the shield. Figure 1.a shows the situation for the examiner when using a radiation protective shield without curtain.

A) Examiner B) Patient C) Image field D) Radiation protective shield without curtain

In addition to physical measurements, the situation was simulated with the same parameters using the Monte-Carlo method.

The measurements were carried out using a C-arm "AXIOM Artis" (Siemens Healthcare) on an Alderson Rando Phantom with pulsed fluoroscopy at 6 pulses/s. The pulsed current was 249 mA, the tube voltage 76 kV. The beam geometry was posteroanterior.

SOLUTION

Marked Reduction of the Escaped Radiation

from underneath the shield with MAVIG's optimised radiation protection concept:
Radiation protective shield with an overlapping panel curtain

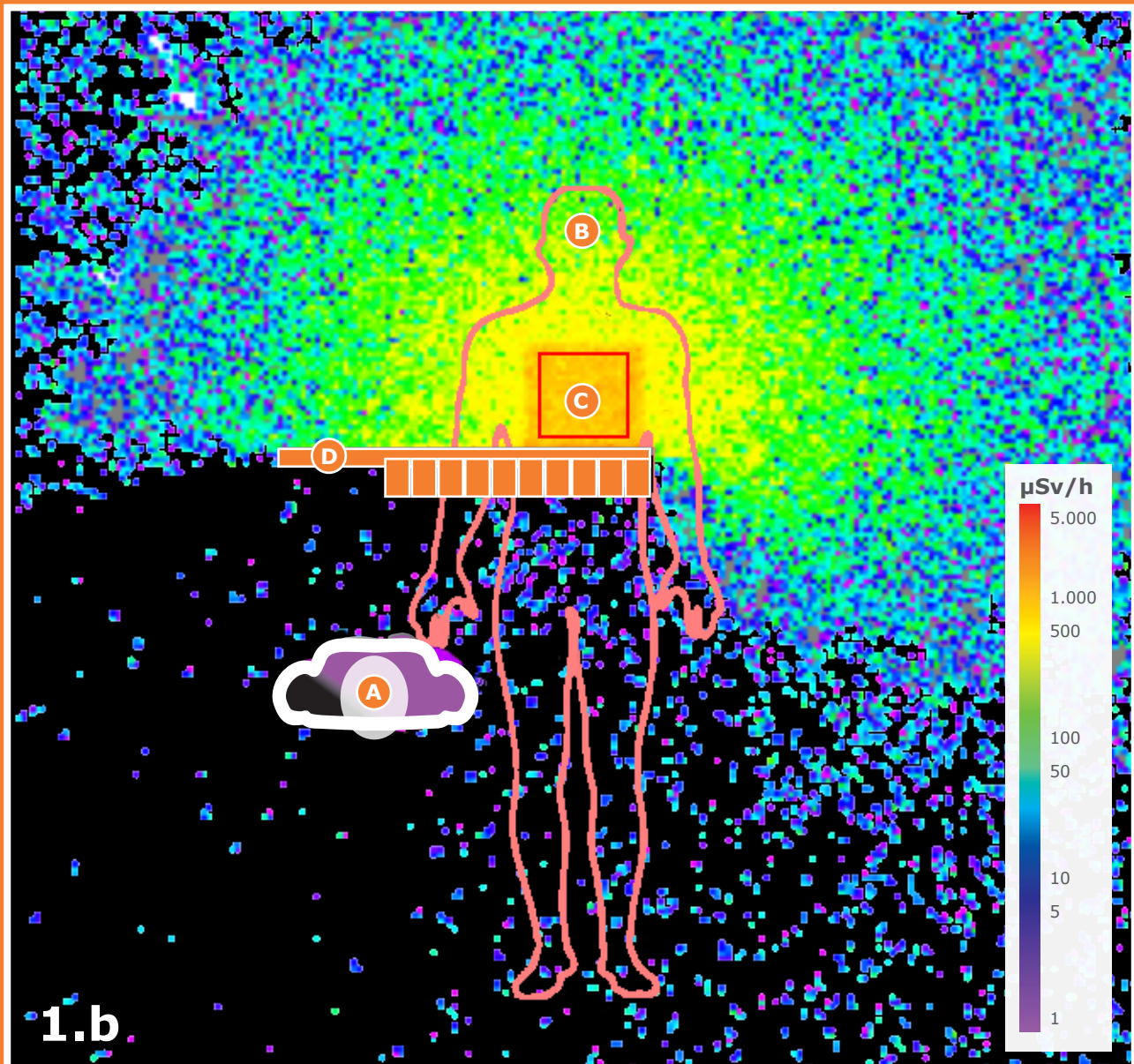

Figure 1.b clearly shows that the radiation exposure for the examiner and other medical personnel behind the shield is considerably reduced by using the newly developed radiation protective shield with overlapping panel curtain.

A) Examiner B) Patient C) Image field D) Newly conceptualised radiation protective shield with overlapping flaps

In the Monte Carlo method the "physical fate" of X-ray photons (here $10^9 = 100$ billion) is followed individually until the initial energy has finally been completely absorbed by matter. The simulation graphic shows the results in a section plane 160 cm above the floor. The coloured pixels are coded according to dose (see colour scale).

A Plus in Radiation Protection

I. Elimination of Underpassing Radiation

CHALLENGE

The most serious problem in the application of radiation protection up till now has been the release of radiation from below.

This results from the scattered radiation originating in the patient volume radiographed, a considerable proportion of which travels through the patient's body tissue. The examiner is thus exposed to the scattered radiation that has traveled underneath the shield and then exited the patient's body. This escaped radiation from below cannot be avoided, even if the shield is positioned tightly against the patient.

There is a further increase of scattered radiation at the position of the examiner and assistant, if the shield has a rigid cut-out for the body, and therefore can not stay in direct contact with the patient's body. This can often be seen in practice. The greater the distance between the protective shield and the surface of the body, the larger the increase in radiation exposure.

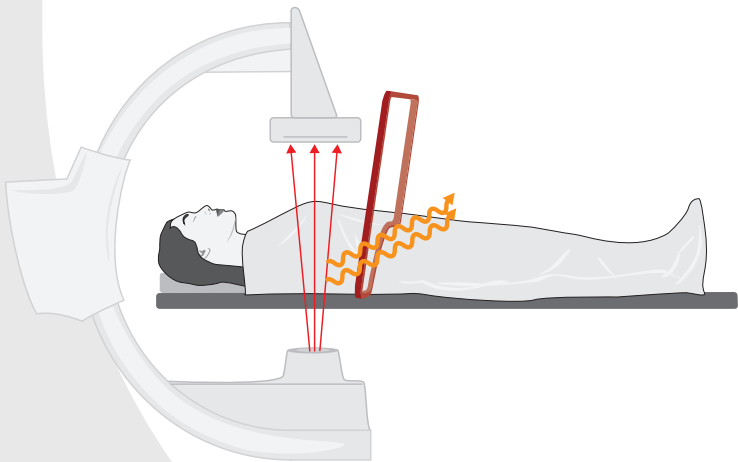

Fig.2.a Protective Shield without Curtain
Scattered radiation originating in the body of the radiographed patient escapes from underneath the protective shield in the direction of the examiner.

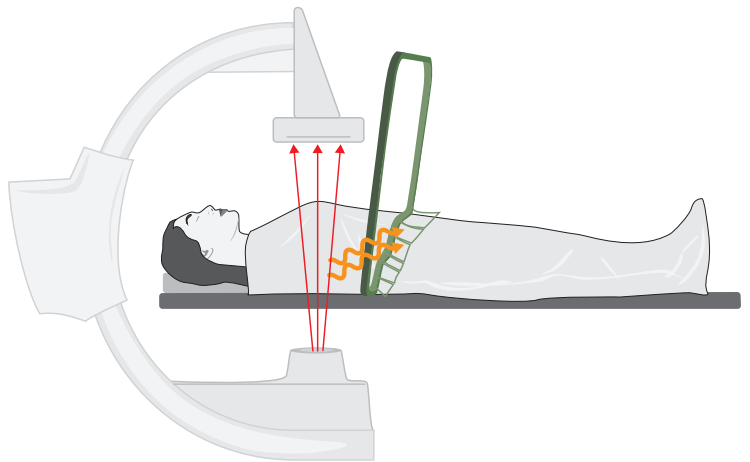

Fig.2.b Protective Shield with Overlapping Panel Curtain
The overlapping panels laying flush on the patient's body stop the scattered radiation leaving the patient in the direction of the examiner. The release of radiation from below in the direction of the examiner is greatly reduced.

SOLUTION

The flexible panel curtain lays perfectly flush to the patient's body when the protective shield is positioned and stops a significant proportion of the scattered radiation coming from the patient's body. At the same time the gap between the shield and the surface of the patient's body is closed. (Fig. 2.b).

Measurements and simulations have shown that this can reduce the dose rate where the examiner stands by up to 85%. The effect where the assistant stands is similarly high. The performance of the protective shield alone is therefore considerably increased by the overlapping panel curtain.

Ideally, the whole length of the panels, but at the very least half the length, should lie on the surface of the patient's body. The special cut arrangement of the overlapping panels prevents gaps from appearing when the individual panels are spread.

Simulation to Prove the Effectiveness of the Overlapping Panel Curtain

In order to test the efficiency of a shielding curtain, the scattered radiation distribution was simulated using the Monte Carlo method for the new radiation protective shield both with and without a curtain. See fig. 1.a and 1.b on pages 6 and 7.

The following illustrations 3.a and 3.b also describe the results.

The effectiveness of the curtain immediately becomes clear. Without the additional curtain, the dose rate in the area of the examiner's upper body (left-hand figure) is many times higher than the dose rate with the curtain (right-hand figure), which because of the specially shaped body cut-out, are not just on the patient's body but also to the side of it.

- ▶ The protection for the examiner's upper body has increased 85% compared with the shield without a curtain.



Fig.3.a Situation for the examiner with the new protective shield *without* a curtain: The light blue area indicates a high exposure dose in the upper body area as a result of the radiation that has traveled underneath the radiation protective shield.

Fig.3.b Situation for the examiner with the new protective shield *with* a panel curtain: The purple area indicates a significantly lower scattered radiation dose in the upper body area.

Conclusion: *The radiation exposure where the examiner and assistant stand (at a height of 160 cm) is reduced by a factor of 6 by using the new shield concept with an overlapping panel curtain compared to the shield alone.*

This represents a dose reduction of 85%.



**With our system, only the sterile disposable cover ends up in the trash.
Not the radiation protection product!**

MAVIG radiation protective drapes can be used more than once and therefore offer substantial economic and environmental advantages compared with disposable radiation protection products.

Further Dose Reduction by a Third Due to the Radiation Protective Drapes

- Radiation protection covers, “drapes”, that are positioned on the patient extend the protection of the curtain. With the use of drapes, considerably more of the scattered radiation coming from the radiographed mass of the patient’s body is blocked and the protection of the curtain is accordingly further increased.
- The protective zone becomes considerably larger. This provides better protection not just for the examiner, but also for the co-examiner and assistant in the room. When compared to using the shield with just the curtain, the radiation exposure is reduced by

a further 30 – 40%.

- ▶ *The best possible reduction in radiation exposure for the examiner and assistant is achieved by combining the shield with curtain with one of the radiation protective drapes.*

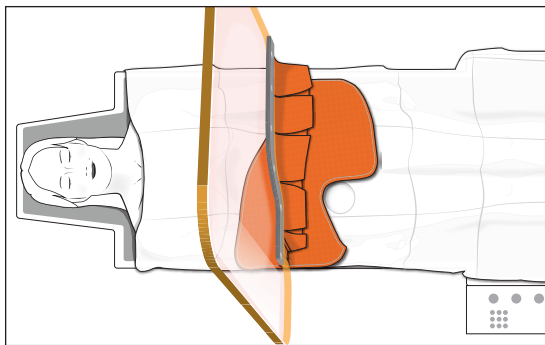

Fig.4.a Radiation protective drape specifically for femoral puncture

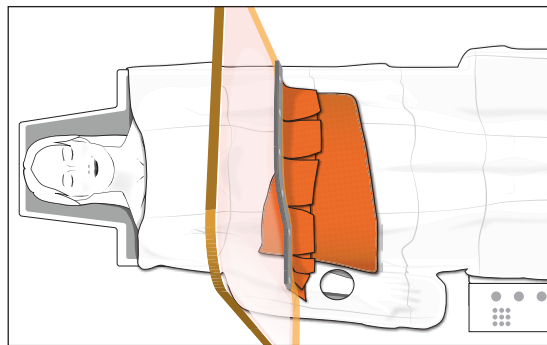

Fig.4.b Radiation protective drape designed for radial puncture

The shape of each drape is designed specifically for its intended purpose: With a cut-out for **femoral puncture** and without a separate cut-out for **radial puncture**.

At the same time, the **special cut** of the drapes avoids them entering into the image area during angulation. The **optimally defined size** of the drapes ensures consistent protection for the examiner, maximum comfort for the patient, and quick and easy removal of the drapes in an emergency. This is also aided by the sterile disposable covers, which make it possible to place the drapes on top of the sterile patient cover.

The fact that the drapes are **two-coloured** (mandarin for the examiner’s side, titan for the patient’s side) prevents them from being positioned incorrectly and so prevents a possible disturbance in the image field.

II. Reduction of the Exposure Dose for Radial Artery Access

CHALLENGE

Access via the radial artery is being chosen with increasing frequency over the femoral artery.

Current radiation protective shields have to be moved more to the side for radial access, resulting in large gaps in the protective zone. The scattered radiation reaches the examiner and assistant unhindered through these gaps.

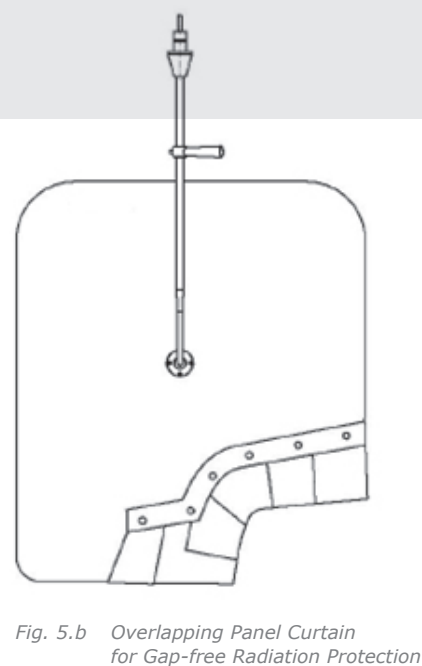
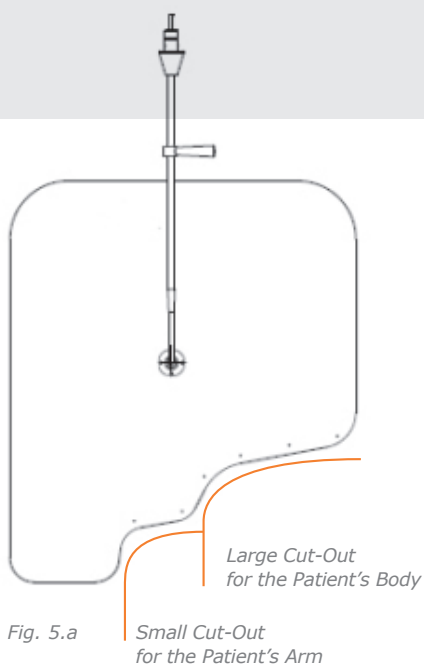

The new radiation protection solution ensures consistent performance in radiation protection for both femoral artery and the radial artery access.

SOLUTION

The new radiation protective shield has **two curved cut-outs** (Fig. 5.a).

The **large cut-out** follows the contour of the **patient's body**, and a second **smaller cut-out** allows for the **patient's arm** to be placed underneath it.

To provide the best possible protection during procedures using the femoral artery, the overlapping panels ensure that the arm cut-out, which is not in use, remains completely closed.

For procedures using the radial artery, the panels spread out so that the puncture site is exposed but the curtain does not offer any gaps through which the scattered radiation might reach the examiner.



Rounded corners and edges and shatter proof materials minimise the risk of injury to personnel or patients.

- Extensive protective zone without gaps
- Optimal fit of the shield and curtain to the patient's anatomy
- Minimised risk of injury for personnel and patients due to the rounded corners and edges of the protective shield and the high level of safety against breakage.

Freedom to Move

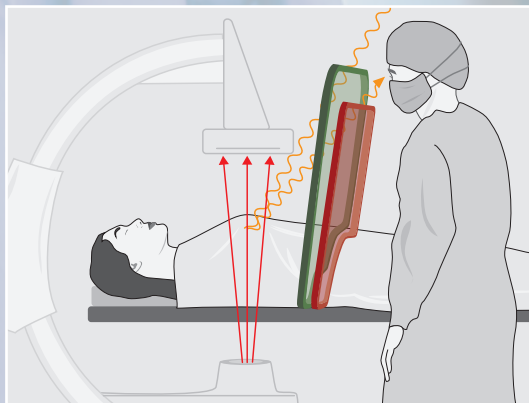

Fig. 6: Better Height Protection for the Examiner
(Red shield: radiation protective shields currently in use; Green shield: MAVIG's new radiation protective shield)

III. Optimal Shielding

People are not all the same. A classic example is height.

With the radiation protective shields used at present, it is particularly possible that the head of a tall examiner can protrude above the shield, meaning that the top part of their skull is unprotected (fig. 6, red shield). But it is precisely this part of the body, in particular the eyes, that especially requires protection due to its high sensitivity to X-rays.

- ▶ This is of great significance since the ICRP reduced the **maximum dose for the lens of the eye to 20 mSv/a** in its recommendation.

CHALLENGE

IV. Increased Freedom of Movement and Enlarged Protective Zone

During a complex intervention, people do not always stay behind the radiation protection necessary for that procedure. The examiner turns and changes his/her position or posture depending on the procedure.

In doing so, the user may not always be in the ideal position exactly behind the protective shield. Parts of the body, especially those parts that are not covered with personal protective equipment (e.g. shoulders, arms, hands), are then exposed to considerable radiation.

If several doctors and assistants are with the patient, they are often not protected by conventional protective shields because of their small radiation shadow.

CHALLENGE

The new radiation protective shield from MAVIG offers an extremely effective solution for each of these challenges:

- By making the area of protection higher (fig. 6, green shield), even examiners up to 195 cm (6'4) tall are very well protected. The increased width and the resultant increase in the **radiation shadow** mean that changes in the examiner's position do not increase the exposure dose.
- The radiation protective shield's new dimensions provides the user with **greater freedom of movement**, without becoming unwieldy due to the extra size. The other medical personnel standing next to the examiner are also better protected.
- Because it is attached with a ball-and-socket joint, the shield can be **rotated and tilted easily** and can be adjusted to the optimal position on the patient and according to every applicable situation.

SOLUTION



MAVIG – for Safety and Innovation



Summary

Radiation Reduction

The diagram shows the exposure dose of the examiner when using various radiation protective measures relative to the exposure dose of the examiner when no radiation protective measures are used.

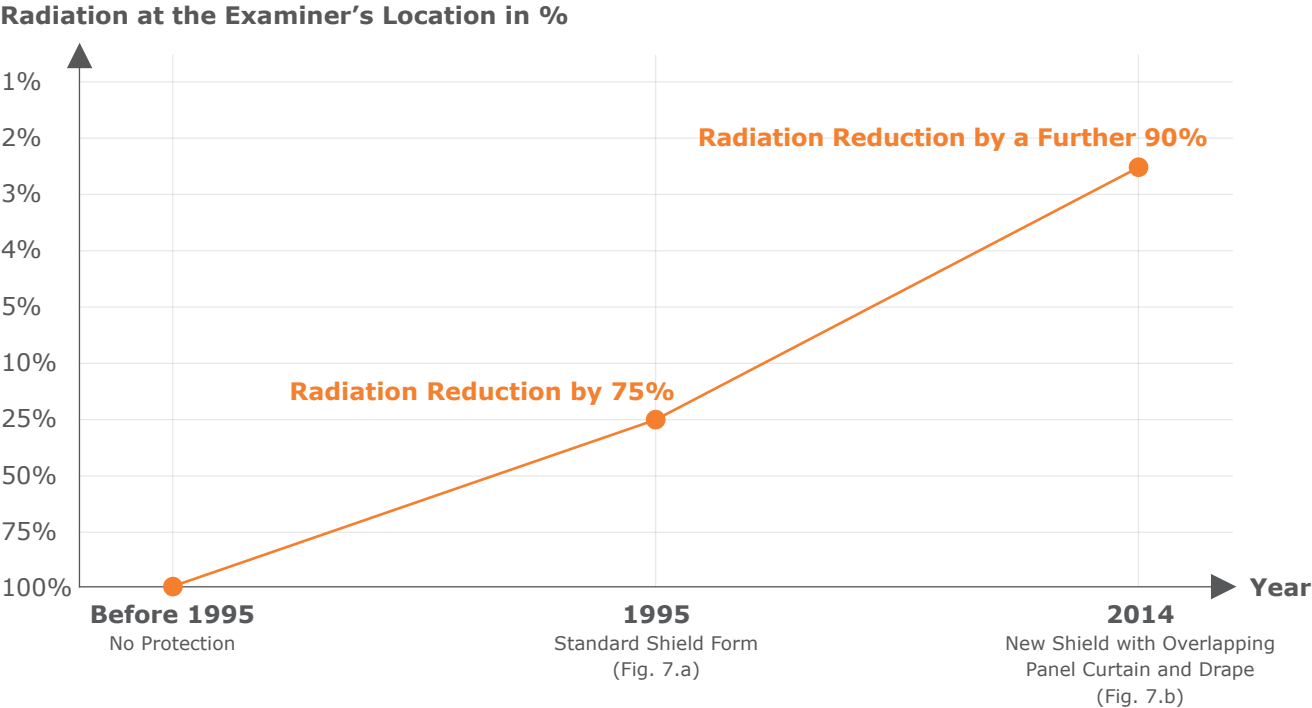

Fig. 7.a Standard Shield Form Since 1995



Fig. 7.b New Radiation Protection Concept Consisting of Radiation Protective Shield with Panel Curtain and Drape

Advantages

- ▶ Minimisation of scattered radiation exposure to the examiner and assistant due to the panel curtain and drapes
- ▶ Reduced burden on the personnel when wearing lighter protective clothing because of the double protection from exposure to scattered radiation (panel curtain, drape)
- ▶ Protection of the head (ocular lens!) even for tall examiners
- ▶ Greater freedom of movement within safe, protective zones for the examiner as well as for other personnel
- ▶ Simple integration of the radiation protection concept into room planning and especially into existing rooms where Portegra2 ceiling-mounted systems are already in place
- ▶ Optimally designed for use in both femoral and radial access procedures

The New Above-Table Scattered Radiation Protection Concept

for radial and femoral access leads to a significant improvement in radiation protection by a **factor of 10** for the user as well as for the assistance personnel compared with the current situation.



Fig. 8.a Front View

Fig. 8.b Side View

Perfect Integration due to Compatibility with the Portegra2 Systems

The total weight falls within the weight range limit of the Portegra2 equipment suspension system. The new protective equipment can therefore be easily integrated into room planning, or retrofitted into existing installations.

MAVIG's patented suspension arm provides the flexibility and safety for which we are known across the industry.

Technical Specifications

Radiation Protective Shield for Femoral and Radial Access During Coronary Angiographies and Interventions

OT54001

Lead acrylic shield centrally mounted with connecting component and Portegra2 suspension arm (length of the extension arm 75 cm, length of the spring arm 91 cm), shield with shaped patient cut-out for use for radial or femoral access with flexible radiation protective curtain, includes 1 box of sterile disposable covers STEA-OT4.

OT94001

Same as OT54001 but with a 95 cm extension arm.

Dimensions	Shield measurements	78 x 90 cm (W x H)
	Length of extension arm	75 cm (OT54001)
	Length of extension arm	95 cm (OT94001)
	Length of spring arm	91 cm
Weight	Shield with panel curtain	15.00 kg
Lead equivalent	Shield	Pb 0.50 mm
	Panel curtain	Pb 0.50 mm
Accessories	STEA-OT4 Box of 50 sterile disposable covers for OT54001 and OT94001	

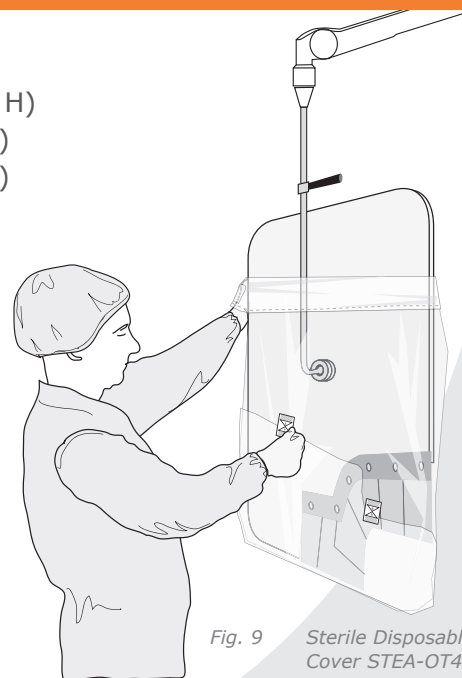

Fig. 9 Sterile Disposable Cover STEA-OT4

- ▶ The high quality of the radiation protective shield made from lead acrylic allows optimal transmission and therefore a clearer view. Rounded corners and edges of the lead acrylic shield and the high level of resistance against breaking minimise the risk of injury to staff and patients.
- ▶ The panel curtain is made of a highly flexible, radiation protective material and covered with a suitable textile outer material. Attached with press studs, it can be removed easily and cleaned like normal radiation protective clothing.
- ▶ Specially shaped, transparent disposable covers are available so that the shield and the panel curtain can be used under sterile conditions. Conventional disposable covers are not suitable as they will restrict the protective panels from moving freely.

Radiation Protective Cover

The covers are made from a highly flexible radiation protective material with a suitable textile outer cover and can be cleaned like a conventional radiation protective apron. The exposure of the examiner can also be reduced, although to a lesser extent, when used in combination with other shields.

ST-FS5AMM

Femoral Drape, with Cut-Out



ST-RZ5AMM

Radial Drape, without Cut-Out



Lead equivalent Pb 0.50 mm

Pb 0.50 mm

Width 75 cm

75 cm

Accessories STEA-FSAM
Box of 50 sterile, semi-transparent disposable covers for ST-FS5AMM

STEA-RZAM
Box of 50 sterile, semi-transparent disposable covers for ST-RZ5AMM

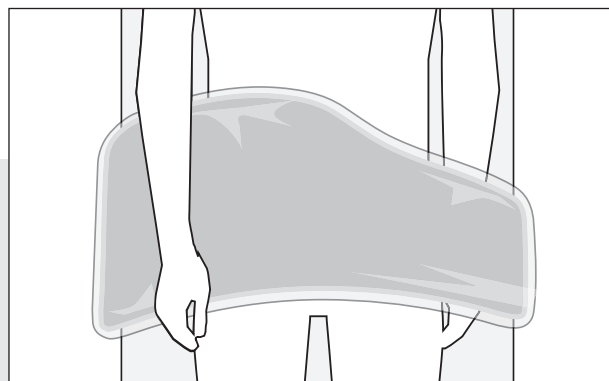
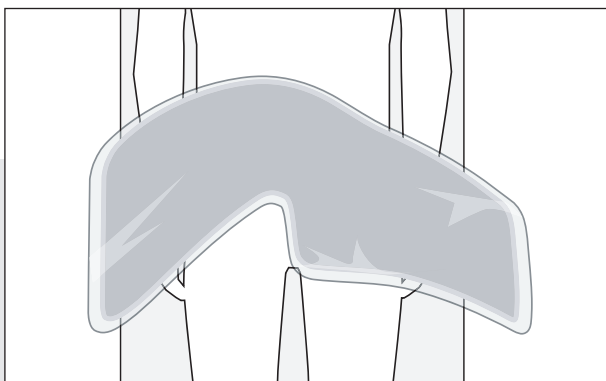

Fig. 10.a Sterile disposable cover STEA-FSAM
Cover for femoral drapes.
Suitable for ST-FS5AMM.

Fig. 10.b Sterile disposable cover STEA-RZAM
Cover for radial drapes.
Suitable for ST-RZ5AMM.



Best Performance in Radiation Protection & Hygiene

Specially developed sterile disposable covers are available for all components presented in the new radiation protection concept for femoral and radial access. They have been designed for to the particular requirements of those components.

By using these specific sterile covers, you ensure that the important characteristics and functions of the products will not be impaired.



WORLDWIDE MAVIG OFFICES

MAVIG GmbH Headquarters

MAVIG GmbH
X-Ray Protection and
Medical Suspension
Systems Stahlgruberring
5
81829 Munich
Germany
PO Box 82 03 62
81803 Munich
Germany
Phone +49 (0) 89 / 420
96 - 0 Fax: + 49 (0) 89 /
420 96 - 200 e-Mail
info@mavig.com
www.mavig.com
ТОВ „ОНКОМЕДИКА“
Уповноважений
представник в Україні
01014, Україна, м. Київ,
вул. Звіринська, 63
+38 (044) 228 84 17
+38 (097) 959 10 89
info@oncomedica.ua
www.oncomedica.ua
www.mavig.com.ua

Nordic & Baltic Countries MAVIG Nordic

Stockholm
Sweden
Phone: +46 (0) 722 25 25 68
e-Mail: larsson@mavig.com

Benelux, GB, Ireland MAVIG B.V.

Dunne Bierkade 28
2512 BD Den Haag
Netherlands
Phone: +31 (0) 70 345 99 85
Mobile: +31 (0) 61 595 43 48
e-Mail: simmonds@mavig.nl

France MAVIG France SAS

66, Ave. des Champs Elysées
F-75008 Paris
France
Phone: +33 (0)1 30 59 46 23
Fax: +33 (0)1 30 59 46 23
e-Mail: info@mavig.fr

China MAVIG Healthcare Beijing Co., Ltd.

Liang Ma Qiao Road 42
Chaoyang District, Beijing 100027
China
Phone: +86 - 10 - 84 41 86 52
Fax: +86 - 10 - 84 41 86 52
Mobile: +86 - 13 70 122 85 86
e-Mail: zhang@mavig.com

REPRESENTATION

USA & Canada Ti-Ba Enterprises, Inc.

25 Hytec Circle
Rochester, NY 14606
USA
Phone: +1 (1) 585 247 1212
Fax: +1 (1) 585 247 1395
(international)
1 800 836 8422
(in the USA)
e-Mail: mavig@ti-ba.com

Middle East & Northern Africa Mena Medical Development

Ashrafieh – Adlieh Square – Alfaras St.
- Alboustany Building, 5th floor
Beirut
Liban
Phone: +961 14 23 499
Fax: +961 14 26 499
e-Mail: mavig@mena-md.com

www.mavig.com